

NO.	QTY.	DESCRIPTION	MODEL NUMBER			STANDARD SEAL KIT	FLUOROCARBON SEAL KIT
			41-5202-2X	41-5205-2X	41-5211-2X		
1	1	BUTTON HEAD CAP SCREW	21-5000-08	21-5000-09	21-5000-10	NO	NO
2	1	WIPER, ROD (FLUOROCARBON)	39-0530-04	39-0530-01	39-0530-00	YES	YES
3	1	BACK-UP RING, ROD	39-F540-00	39-F540-01	39-F540-02	YES	YES
4	1	SEAL, ROD (STANDARD)	39-0100-38	39-0100-20	39-0110-46	YES	NO
	1	SEAL, ROD (FLUOROCARBON)	39-0520-14	39-V100-20	39-V110-46	NO	YES
5	1	PLUG	43-0680-04	43-0680-04	43-0680-06	NO	NO
6	2	O-RING, MANIFOLD MOUNT	39-0500-42	39-0500-42	39-0500-42	YES	NO
	2	O-RING, MANIFOLD MOUNT (FLUOROCARBON)	39-0510-25	39-0510-25	39-0510-25	NO	YES
7	2	BUTTON HEAD CAP SCREW	21-5000-18	21-5000-18	21-5000-19	NO	NO
8	1	WASHER	21-5002-00	21-5002-00	21-5002-00	NO	NO
9	1	BALL SEAT ASSEMBLY	90-1999-88	90-1999-89	90-1999-90	YES	YES
10	1	BALL, STEEL ALLOY	23-6000-14	23-6000-11	23-6000-02	YES	YES
11	1	PLUNGER	47-5105-00	47-5109-00	47-5113-00	NO	NO
12	1	SEAL, PLUNGER (STANDARD)	39-0100-37	39-0100-18	39-0110-30	YES	NO
	1	SEAL, PLUNGER (FLUOROCARBON)	39-V100-37	39-V100-18	39-V110-30	NO	YES
13	1	O-RING, RETAINER (FLUOROCARBON)	39-V000-36	39-0510-31	39-V510-43	YES	YES
14	1	RETAINER	81-4000-28	81-4000-29	81-4000-30	NO	NO
N/A	N/A	SEAL KIT (STANDARD)	46-1502-05	46-1502-02	46-1502-03	INCLUDED IN KIT	
N/A	N/A	SEAL KIT (FLUOROCARBON)	46-V502-05	46-V502-02	46-V502-03		

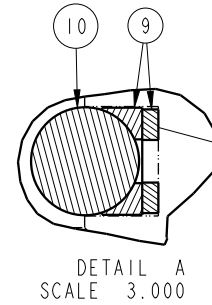

### PARTS LIST

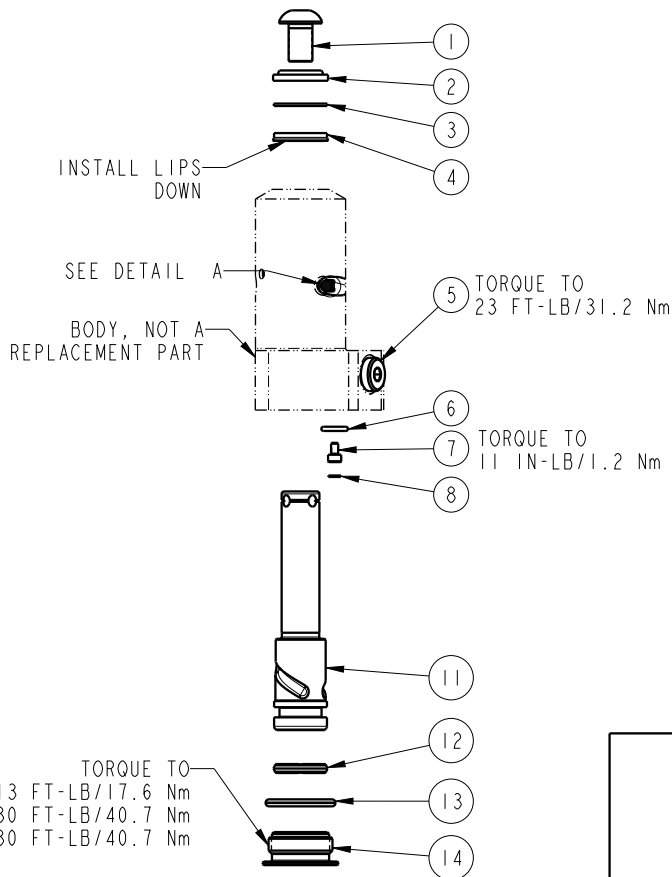

VEKTEK, INC.  
1334 E. SIXTH AVE. P.O. BOX 625  
EMPORIA, KS. 66801 U.S.A.

#### ASSEMBLIES AFFECTED

41-5202-23, 41-5205-23, 41-5211-23  
41-5202-24, 41-5205-24, 41-5211-24  
41-5202-26, 41-5205-26, 41-5211-26

SIZE  
A

MPL1544

REV  
B

B	5803	RELEASE	JDW	09/04/25
REV	IN ACCORDANCE WITH ECN	EFFECTIVE DATE	REVISED BY	DATE
DRW BY:	NPETERS	DRAWING STATUS: <b>Released</b>		
DATE:	8/9/21	PRODUCTION APPROVED FOR RELEASED STATUS ONLY		